



Patented* coil and electronic circuitry design provides virtually *no zero drift* and *highly repeatable* flow measurement data

Choice of aluminum or stainless steel construction for ruggedness and reliability

Performance and affordable price mean great value

DESCRIPTION

The Model 80 Series Flo-Controllers will precisely measure and control flow rates of virtually any clean, dry gas as low as 0-20 sccm or as high as 0-10 LPM (0-20 SCFH). Repeatable results are achieved by utilizing a patented* thermal mass flow sensor design. This proven design minimizes zero drift while maintaining fast response and linear outputs.

Metal compression tube fittings provide fast gas connections and work well with metal or plastic tubing. Electrical connections are made via the included 3 foot cable. The units are available with or without a display for a wide range of applications.

The Model 80 and 80D are constructed from aluminum; the Model 80S and 80SD are constructed from stainless steel. The Model 80D and Model 80SD feature an integrated 3½ digit display for flow rate monitoring right on the unit.

TABLE OF CONTENTS

Principle of operation	2
Power, signal & display configurations	2
Detailed specifications	3
Dimensions.....	4
Ordering information.....	5
Other related products.....	6

ZERO DRIFT

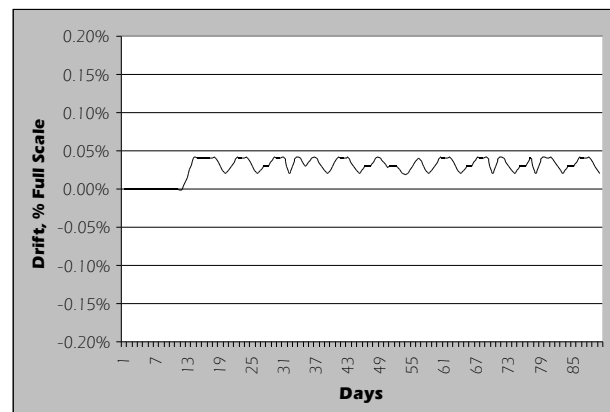

Tests run on a new, randomly chosen McMillan thermal mass flow sensor. Temperature ranged from 20-24 degrees C during testing.

*US Patents 6,038,921 & 6,240,776. Other patents pending.

PRINCIPLE OF OPERATION

Thermal mass controllers feature fast response, virtually zero maintenance, and precise measurement - all very important qualities among today's variety of applications.

The McMillan Company Model 80 Series Flo-Controllers utilize this thermal sensing technology. Flow enters the unit, and a portion of the flow is redirected into a small tube. This tube has two coils, one downstream from the other. Each coil is heated, and, as the gas passes through the tube, the smart electronics sense the amount of heat transferred from one coil to the other. McMillan Company's patented system insures that the zero remains stable and the sensor is extremely repeatable.

Flow then passes into the proportional solenoid valve. This valve is controlled by the active servo electronics, which compare a setpoint (either internal or provided by the customer) to the actual flow rate provided by the flow sensor and adjust the valve accordingly.



Figure 2. Sensing coil design.

The output of the thermal mass flow sensor is directly related to the specific heat characteristic of the gas being measured. Therefore, if a unit is calibrated for air, it is a relatively simple calculation to figure the calibration for nitrogen or some other similar gas. This advantage offers flexibility not found on many other types of flow sensors.

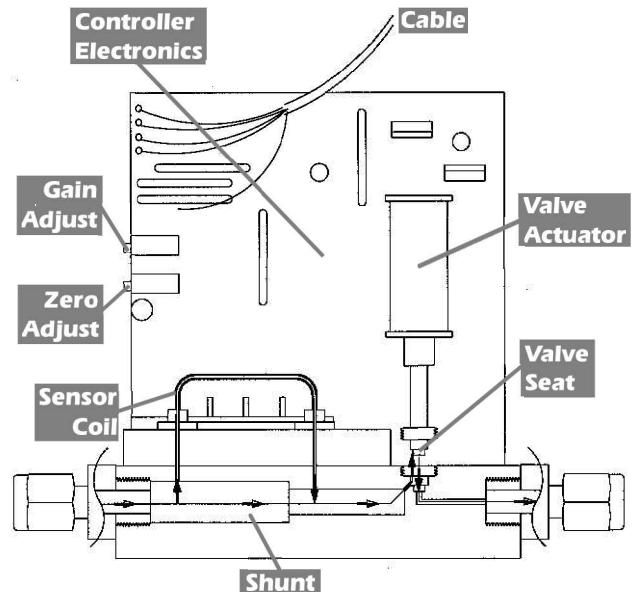

Figure 1. Flow controller design.

POWER, SIGNAL & DISPLAY CONFIGURATIONS

All Model 80 Series Flo-Controllers require 12VDC power, either from a power adapter package or other external power supply. All feature 0-5 VDC input and output signals where 0 VDC represents zero flow and 5 VDC represents 100% rated flow.

The Model 80 Series Flo-Controllers include an attached 36" cable for signal and power connections. This cable is terminated in a mini-DIN (PS/2 type) connector. Either a mating cable (P/N: 50-C-X) or power adapter package (115VAC P/N: C-115VAC, 230 VAC P/N: C-230VAC) is required for operation.

The Model 80D and Model 80SD feature an integrated 3½ digit LCD display to indicate flow rate in engineering units (sccm, L/minute, or SCFH), in addition to the standard 0-5 VDC output. These modules also come standard with internal setpoint circuitry - the user may elect to disable the external 0-5 VDC setpoint signal and adjust the desired setpoint using the provided potentiometers on the front panel.

The Model 80D and Model 80SD can be calibrated for up to 3 different gases or gas blends. Using switches located on the front panel, the user may select which gas to measure and the unit will adjust accordingly. NOTE: Calibration for only one gas is standard. Additional gases may incur additional charges.

DETAILED SPECIFICATIONS

Accuracy/Linearity: ±1.5% Full Scale*

Repeatability: ±0.25% Full Scale*

Power Requirements: Model 80, 80S: 12-15 VDC @ 230 mA
Model 80D, 80SD: 12-15 VDC @ 250 mA

Pressure Rating: Over pressure limit is 150 psig (10.2 bar)
For best operation, keep differential pressure within 15-40 psig.

Temperature Rating: Operating range: 0 to 55°C (non-condensing)
Storage range: 0 to 70°C

Temperature Sensitivity: ±0.15% Full Scale* or less per °C

Wetted Materials: Model 80, 80D: Aluminum, stainless steel (304, 316), and Viton® O-rings.
Model 80S, 80SD: Stainless steel (303, 304, 316) and Viton® O-rings.

Recommended Filtration: 10 microns or less

Compatible Gases: Most clean, dry gases that are compatible with the wetted materials.

Outputs: Analog voltage output -- 0-5VDC. Voltage level is proportional to flow rate (zero VDC at zero flow). Load connected to output should not be less than 2500 ohms.

Setpoint Input: Model 80, 80S: Analog voltage input, 0-5 VDC. Voltage level is proportional to flow rate (zero VDC is zero flow). Input load approx. 2 meg ohms.
Model 80D, 80SD: User selectable internal or external.
External: Analog voltage input, 0-5 VDC. Voltage level is proportional to flow rate (zero VDC for zero flow). Input load approx. 2 meg ohms.
Internal: Front-panel adjustable with two trim pots, one coarse and one fine adjustment.

Reliability: Units installed as recommended by the manufacturer can be expected to remain in service at least 5 years (43,800 hours) before maintenance. Longer MTBF may be experienced in many applications. For best accuracy, factory calibrations should be performed every 12 months.

Flow Connections: Metal compression tube fittings included. All ports are 1/8" NPT. Models 80 and 80D come standard with brass fittings; Model 80S and 80SD come standard with stainless steel fittings.

Electrical Connections: Integrated, 3-ft, 6-conductor cable, terminated with 6-pin male mini-DIN connector (PS/2 style). Mating cable and power adapter packages are available - see options under Ordering Information.

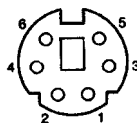

- Pin #1:** Signal output common
- Pin #2:** Power (+12 to +15 VDC)
- Pin #3:** Signal output (0-5 VDC)
- Pin #4:** Setpoint input (0-5 VDC)
- Pin #5:** Control input common
- Pin #6:** Power common (ground)

*Full Scale is from 10% to 100% of rated flow. Linearity is best fit straight line. All calibrations performed with air unless indicated otherwise on provided calibration certificate..

DIMENSIONS

For units without integrated display (Model 80 & 80S):

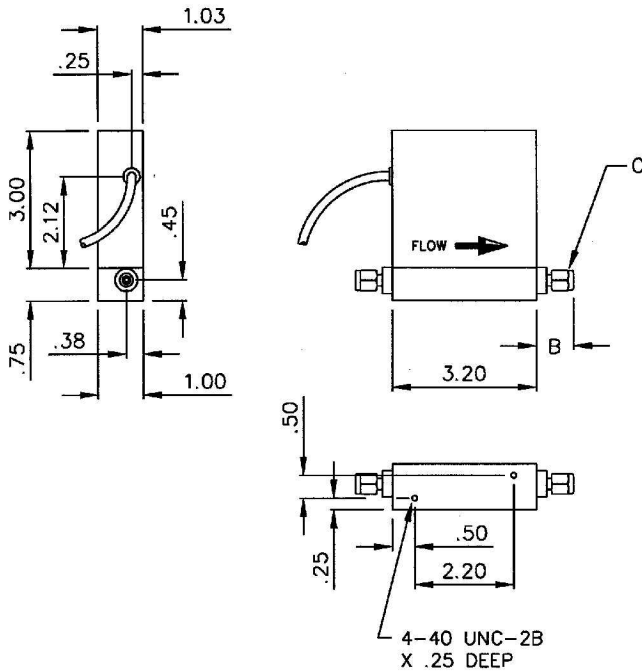

DESCRIPTION	DIM A	DIM B	FITTING C
THRU 1000 SCCM	N/A	1.00	1/8" TUBE FTG
2 L/M THRU 5 L/M	N/A	1.20	1/4" TUBE FTG
10 L/M	N/A	1.30	3/8" TUBE FTG

For units with integrated LCD display (Model 80D & 80SD):

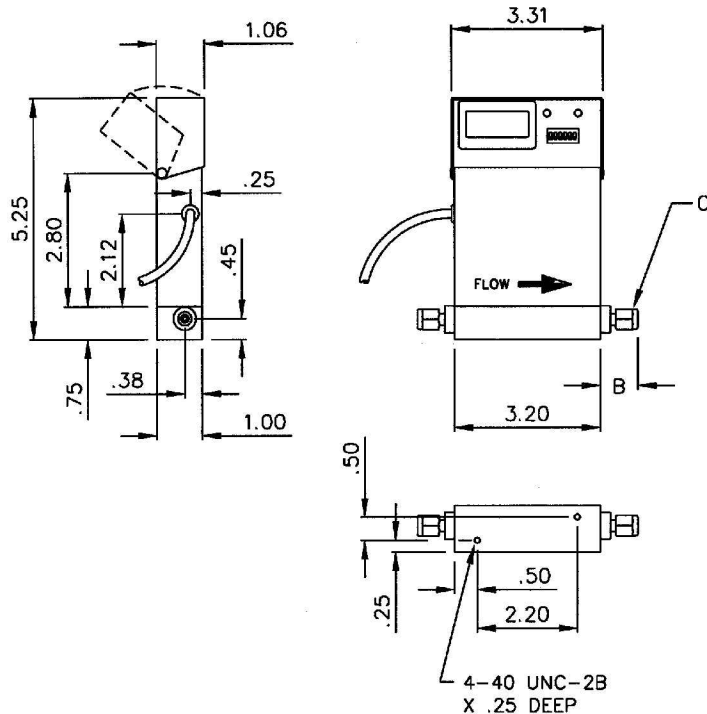

DESCRIPTION	DIM A	DIM B	FITTING C
THRU 1000 SCCM	N/A	1.00	1/8" TUBE FTG
2 L/M THRU 5 L/M	N/A	1.20	1/4" TUBE FTG
10 L/M	N/A	1.30	3/8" TUBE FTG

ORDERING INFORMATION

1. Select a range:

80	80S	80D	80SD	Flow Range*	Tubing Connection**
80-3	80S-3	80D-3	80SD-3	0-50 sccm	1/8"
80-4	80S-4	80D-4	80SD-4	0-100 sccm	1/8"
80-5	80S-5	80D-5	80SD-5	0-200 sccm	1/8"
80-6	80S-6	80D-6	80SD-6	0-500 sccm	1/8"
80-7	80S-7	80D-7	80SD-7	0-1000 sccm	1/8"
80-8	80S-8	80D-8	80SD-8	0-2.0 L/minute	1/4"
80-9	80S-9	80D-9	80SD-9	0-5.0 L/minute	1/4"
80-10	80S-10	80D-10	80SD-10	0-10.0 L/minute	3/8"
80-4C	80S-4C	80D-4C	80SD-4C	0-0.20 SCFH	1/8"
80-5C	80S-5C	80D-5C	80SD-5C	0-0.50 SCFH	1/8"
80-6C	80S-6C	80D-6C	80SD-6C	0-1.00 SCFH	1/8"
80-7C	80S-7C	80D-7C	80SD-7C	0-2.00 SCFH	1/8"
80-8C	80S-8C	80D-8C	80SD-8C	0-5.00 SCFH	1/4"
80-9C	80S-9C	80D-9C	80SD-9C	0-10.00 SCFH	1/4"
80-10C	80S-10C	80D-10C	80SD-10C	0-20.00 SCFH	3/8"

2. Order options & accessories:

Please note that either a power adapter package or cable assembly is required for operation.

Power adapter package: Order C-115VAC package for 115VAC (60 Hz) operation. Order the C-230VAC package for 230VAC (50 Hz) operation. Power adapter packages include ALL of the following components:

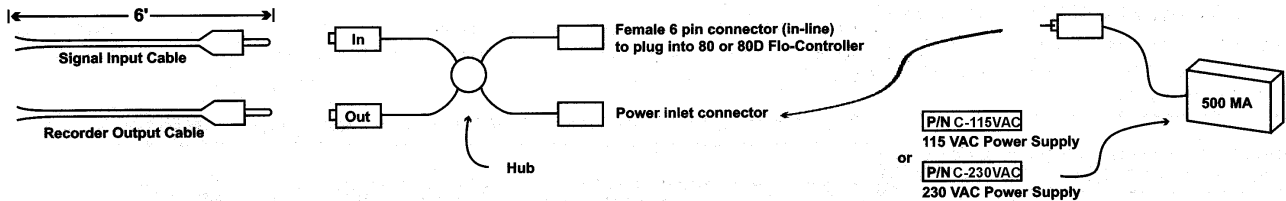

Cable Assembly: Order 50-C-X Cable Assembly for 12-15VDC operation. Includes 3 foot cable, terminated with pigtail leads. Other cable lengths available; contact factory for details.

Stainless steel fittings: Order option FTG-S for Model 80 and 80D to upgrade from brass to stainless steel compression fittings. Stainless steel compression fittings are standard on the Model 80S and 80SD.

Custom Cable Lengths: Custom cable lengths (3 feet standard) & connector options are available. Call for details.

Model 250 Multi-Function Display: 8-digit "smart" display that allows 16-point linearization of flow sensor signal to achieve ±0.5% full scale or better linearity/accuracy. Alarm and setpoint relay options. Totalizer function included.

*All ranges listed are for calibration with air. Other gas calibration may requires different range designations - contact factory for details.

**Other fitting sizes may be available - contact factory for details.

OTHER RELATED PRODUCTS

Model 250 Multi-Function Display

Check out our website
for more information!



Completely programmable flow rate and total flow display, perfect for use with the Model 80 or 80S

Program up to 16 calibration points to achieve precise linearization!

Option cards add alarm & analog outputs, more

Achieve $\pm 0.5\%$ full scale linearity/accuracy when combined with any MFC

Model 401 PTFE Liquid Flow Controller

Call for details today!



Valve Unit

Control Unit

The world's first automatic microprocessor-controlled PTFE liquid flow controller

A flow sensor and automatic needle valve combined

Improve processes by maintaining steady flow rates